

HALF SIZE STEAM TABLE PAN RACKS

- ▶ 1" H x 1½" W Aluminum slides; welded to frame
- ▶ Holds following pan sizes by the lip; full size 20¾" x 12¾", half size 10¾" x 12¾", two-third size 13⅞" x 12¾", one-third size 6⅞" x 12¾"
- ▶ 5" Heavy-duty swivel stem casters (CHV)
- ▶ "KD" Knock Down rack; ships UPS in one box
- ▶ "W" All welded rack; reinforced gusset corners; ships UPS
- ▶ Optional tops available: poly, stainless or aluminum

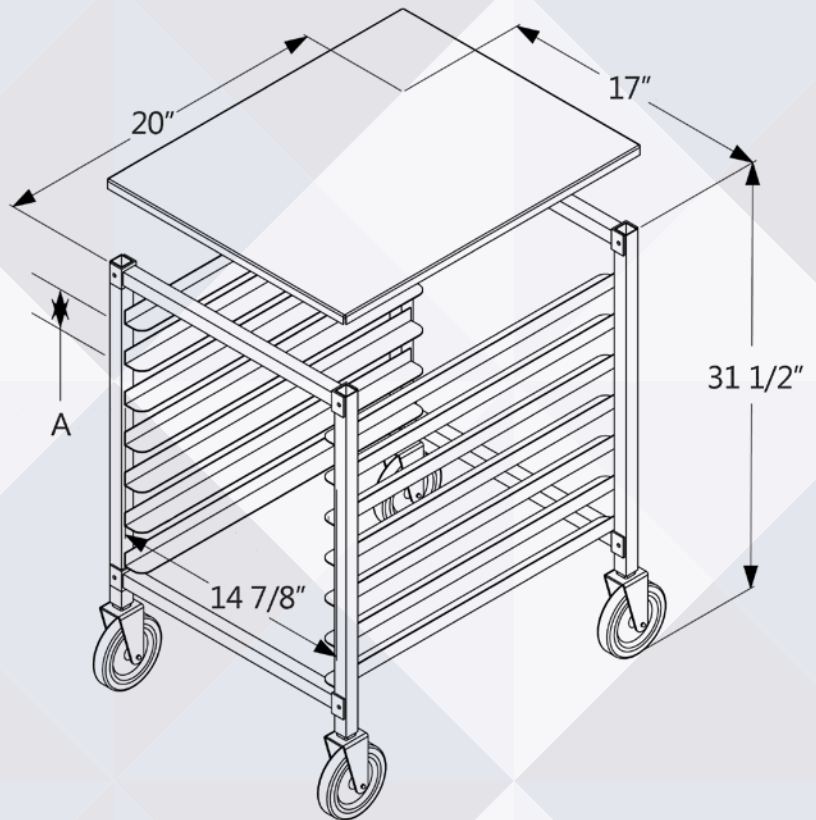

WE3020W-7-SP-ST
(shown with optional stainless top)



Steam Table Pan Racks				
Model Number	Description	Size W x H x D	Shelf Spacing	Pan Capacity
WE3020KD-6-SP	Knock Down End Load	17" x 31½" x 20"	3"	6
WE5020KD-4-SP	Knock Down End Load	17" x 31½" x 20"	5"	4
WE3020W-6-SP	All Welded End Load	17" x 31½" x 20"	3"	6
WE5020W-4-SP	All Welded End Load	17" x 31½" x 20"	5"	4

Options: CL, CHV, CHL, PS, AT, ST, PT – see page 82 for details

