



Prairie View Industries

Quality - Durability - Guaranteed

**RELIABLE
FOOD SERVICE
EQUIPMENT
SINCE 1999**



PRODUCT CATALOG | COMMERCIAL - INSTITUTIONS • PRIVATE

800.554.7267 | pvimanufacturing.com



Corporate Mission and Vision

Prairie View Industries' mission has not changed since 1991 when Richard Allen, (President/Founder), built his very first ramp. It is to help mobility-challenged people lead more active, productive, and happier lives. We strive every day to improve designs for better adaptability in the everyday world. We also encourage customer input and are more than willing to adapt to specific needs.

Our Food Service line was started in 1999 and has grown every year since and is now a leader in the industry. We strive to have the highest quality equipment in both Stainless Steel and Aluminum and the best customer service. We will continue to maintain inventory levels for quick delivery. As in our ramp division, our food service line is growing due to our willingness to listen and build to our customers' needs.

Prairie Views' mission and vision are both quite simple. We are a family-owned company that sincerely want to grow as a family for our company, our employees, our customers, and our community.

Explore our full range of food service equipment at www.pvimanufacturing.com and discover the PVI difference!

SHIP IT COAST TO COAST!

When you place an order with Prairie View Industries, we'll help you determine the option that's right for you. Shipping 3-5 days on stocked items generating better lead times.



BECOME A DEALER!

At Prairie View Industries, we prioritize the customer in all our efforts, fostering long-term relationships built on a mutual dedication to providing a sustainable product that meets specific needs. If this resonates with you, consider becoming a dealer with us. Scan the QR code to begin your journey.

ABOUT US.....	1	POLY BOX.....	19
BREAD & BATTER STATIONS & TABLETOP	3	PLATTER RACK & DONUT SCREEN RACK	20
SLICER/MIXER/SCALE CART.....	4	L SERIES KNOCK DOWN PAN RACKS.....	21
LUG CARTS.....	5	HALF & FULL SIZE CAN RACKS.....	22
TRASH CAN & KEG DOLLY	7	EQUIPMENT STANDS.....	23
TRASH CAN BACK SPLASH.....	7	MOBILE ALUMINUM SHELVING UNITS	24
STAINLESS STEEL TABLES	8	ALUMINUM UTILITY CARTS	26
POLY TOP I-FRAME TABLES.....	9	BULK MOVERS & TUBS	27
STAINLESS TOP I-FRAME TABLES	10	PLATFORM TRUCKS AND FLAT DOLLIES	28
WALL MOUNT SHELVES.....	11	CHILL TRAY DOLLIES	29
KEG SHELVING.....	12	WORKSTATIONS.....	30
DUNNAGE RACKS.....	13	RETRACTABLE PREP STATIONS.....	31
ADJUSTABLE DUNNAGE BRIDGES	14	DRIP CATCHER , RECIPE HOLDER AND CORNER GUARD	32
PIZZA RACKS	15	INDUSTRIES SERVED	33
PIZZA SCREEN HOLDER.....	16	WARRANTY.....	34
NESTING PAN RACK	17		
STEAM PAN RACK	18		

FEATURES

Bread and Batter Stations

- All 300 series stainless steel construction
- Open design for easy cleaning
- Mobile, full size (BBS-F) ships LTL and includes:
 - 2 Cold charge gel trays for holding batter mix
Maintains temperature under 40° F up to 8 hours when food is placed directly in pan
 - 2 Stainless steel, full size steam pans 6" deep
Top pan captures batter mix & bottom pan holds breading mix
 - 2 Perforated baskets
1 Coarse basket for batter
1 Fine basket for breading
- 1 Stainless U-channel to catch drips between pans
- 2 - 5" X 1" swivel stem casters (CV)
- 2 - 5" x 1" locking stem casters (CL)

Stationary Countertop Unit Ships "KD" UPS and includes:

- 2 Base and top frame
- 2 Stainless steel, full size steam pans 6" deep
Back pan captures batter mix & front pan holds breading mix
- 1 Perforated coarse basket for batter and breading
1 Stainless U-channel to catch drips between pans
Top canopy requires minimal assembly

Sheet Pan Wing (BBPW)

- Holds 18" x 26" or 18" x 13" sheet pans by the lip
- Can be mounted on left, right, or both sides



BBS-F



Stationary Countertop



Sheet Pan Wing

Bread and Batter Stations		
Model Number	Description	Size W x H x D
BBS-F	Mobile, Full Size	24 ¾" x 60 ¼" x 29"
BBS-TABLETOP	Countertop	24 ¾" x 25 ½" x 31"
Sheet Pan Wing		
Model Number	Description	Size W x H x D
BBPW	Optional Sheet Pan Wing For BBS-F Model Only	2 7/8" x 22"



WS3026SC-7ST

FEATURES

Slicer/Mixer/Scale Cart

- Designed with you in mind
- Easy clean & easy side load design
- 16 Gauge stainless steel
Removable top, pull out drawer slide
Extends up to 20" out from cart
- 1" H x 1½" W aluminum slides; welded to frame
- Holds two half size deli trays per slide or 18" x 26" full size sheet pans
- Total locking swivel casters, simultaneously locks the swivel & wheel making the unit stationary (CHTLPG-5)
- All welded aluminum frame
Will not rust
No assembly required
- Holds up to 500 lbs. – evenly distributed static load;
Ships UPS

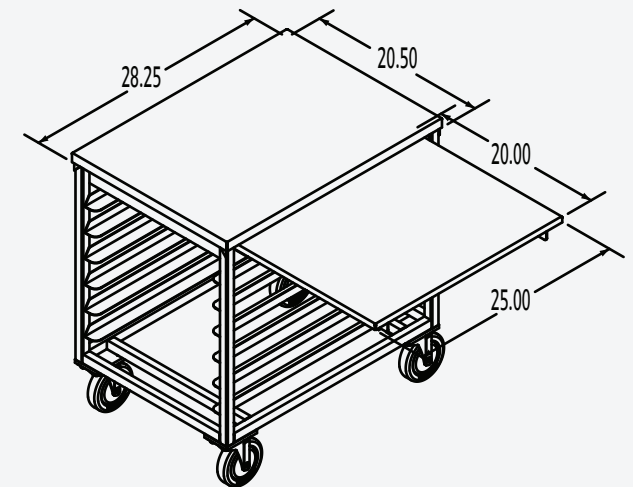

WE3018SC-7ST



Slicer/Mixer/Scale Cart			
Model Number	Description	Size W x H x L	Weight #
WS3026SC-7ST	Side Load	28¼" x 30" x 20½"	50
WE3018SC-7ST	End Load	20½" x 30" x 28¼"	50

FEATURES

Lug Carts

- Work-saving mobile carts use for prepping, transporting and storage of all types of products
- 1½" Diameter, easy grip frame
- Open clean design
- 5" Swivel stem casters (CV)
- Heavy-Duty Luggers (HD) come with :
Two (2) Heavy-Duty rigid plate casters (CHRPG-5)
Two (2) Heavy-Duty swivel plate casters (CHVPG-5)
- All welded aluminum - will not rust
- LUGCT6-KD Ships knock down UPS
- LUGCT6, LUGDB6, HDLUGDB6 and HDLUGDB10 ship LTL
- All others ship UPS

Optional

- Locking casters (CL)
- Heavy-Duty swivel casters (CHV)
- Heavy-Duty locking casters (CHL)
- Lugs (Lug Gray)
- Lids (Gray Lid)

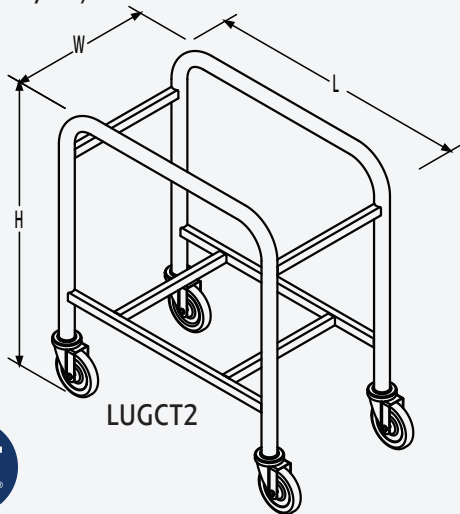

LUGCT2



HDLUGDB6

LUGCT2



Lug Gray Tub



Lug Lid

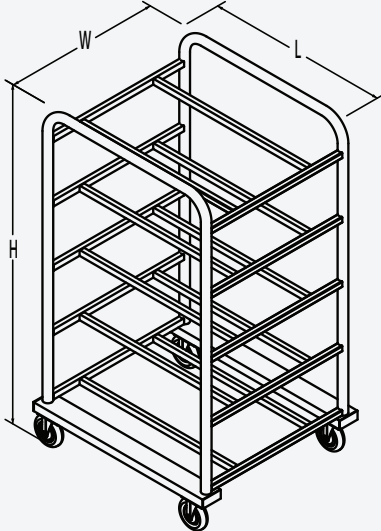

Lug Carts			
Model Number	O.D. Size W x H x L	Lug Capacity	Weight #
LUGCT1	16½" x 20" x 24¼"	1	11
LUGCT2	16½" x 33" x 18½"	2	15
LUGDB2	24½" x 20" x 33"	2	14
LUGCT3	15½" x 43¾" x 28½"	3	17
6 Capacity Lug Carts			
LUGCT6-KD	20" x 70½" x 27"	6	34
LUGCT6	19½" x 73" x 25¼"	6	33
LUGDB6	28½" x 36¾" x 32¾"	6	33
Heavy Duty Lug Carts			
HDLUGDB6	27½" x 35" x 31¼"	6	17
HDLUGDB10	27½" x 57" x 31¼"	10	24
Optional FDA Approved Lug Tub & Lid			
Model Number	Description	Weight #	
LUG GRAY TUB	50 lb. Capacity Gray Lug Tub	3.8	
LUG LID	Gray Lug Lid	1	

FEATURES

Trash Can – Keg Dolly

- Industrial aluminum tabs – secure containers for safe transporting
- Five 3" x 1" casters (CDV3), outer mounted for stability
- 3" Wider than plastic dolly
- Solid aluminum hubs
- Universal design for transporting Brute® or Huskee® round containers or kegs
- Supports 20, 32, 44 and 55 gallon container sizes as well as kegs

Trash Can Back Splashes

- Fits 32, 44, and 55 gallon round containers
- Available in 18 gauge stainless steel or aluminum
- Five tabs hold back splash securely in place
- 18" High and wrap around design keeps floors and walls clean
- Nesting design allows room for inside can liner



D319P



Trash Can Back Splash

TCBS1838SS

Trash Can - Keg Dolly			
Model Number	Size	Weight #	
D319P	19 1/2" x 16 1/2"	6	
Trash Can Back Splash			
Model Number	Description	Size H x L	Weight #
TCBS1838SS	Stainless Steel	18" x 38"	9
TCBS1838AL	Aluminum	18" x 38"	7



ST243424

Stainless Steel Tables		
Model Number	Size H x L	Weight #
ST243424	34" to 35 1/2" x 24"	39
ST243436	34" to 35 1/2" x 36"	50
ST243448	34" to 35 1/2" x 48"	60
ST243460	34" to 35 1/2" x 60"	70
ST243472	34" to 35 1/2" x 72"	80
ST243496	34" to 35 1/2" x 96"	101
ST303424	34" to 35 1/2" x 24"	43
ST303436	34" to 35 1/2" x 36"	54
ST303448	34" to 35 1/2" x 48"	66
ST303460	34" to 35 1/2" x 60"	77
ST303472	34" to 35 1/2" x 72"	89
ST303496	34" to 35 1/2" x 96"	106

S/S Tables w/ 6" Backsplash		
Model Number	Size H x L	Weight #
STBS243424	34" to 35 1/2" x 24"	40
STBS243436	34" to 35 1/2" x 36"	51
STBS243448	34" to 35 1/2" x 48"	62
STBS243460	34" to 35 1/2" x 60"	73
STBS243472	34" to 35 1/2" x 72"	84
STBS243496	34" to 35 1/2" x 96"	106
STBS303424	34" to 35 1/2" x 24"	44
STBS303436	34" to 35 1/2" x 36"	56
STBS303448	34" to 35 1/2" x 48"	68
STBS303460	34" to 35 1/2" x 60"	81
STBS303472	34" to 35 1/2" x 72"	93
STBS303496	34" to 35 1/2" x 96"	117



STBS243424

FEATURES

Stainless Steel Tables

- All Stainless Steel Construction
16 Gauge Top
6" High Optional Back Splash
- Stainless Steel Reinforced Hat Channel
Runs the Complete Table Length
Mounted Stainless Steel Leg Sockets with
a Locking Set Screw
- Adjustable Bullet Feet
Adjusts to 1 1/2"

Optional

- Stainless Steel Under Shelf

Ships Knock Down

- Easy Assembly

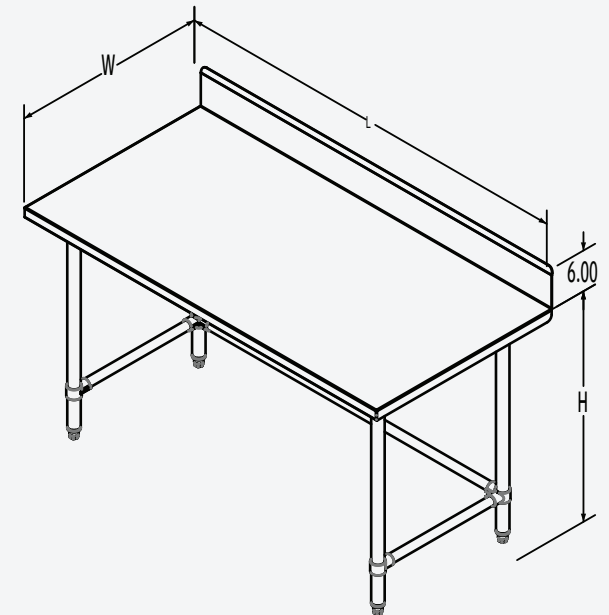

FEATURES

Poly Top I-Frame Tables

- Design a table to fit your needs
- Order with or without backsplash
- Heavy-Duty 3/4" Poly Top
- Sized in 24" x 30" pieces for easy cleaning
- All aluminum frame – will not rust
- Adjustable bullet feet adjust to 1 1/2"
- I-Frame base
- Provides open access from both sides
- Easy lock bushing assembly
- Ships knock down

Optional

- Adjustable 12" deep stainless steel cantilever shelf
- 18" deep aluminum under shelf
- 72" wide and up ship LTL

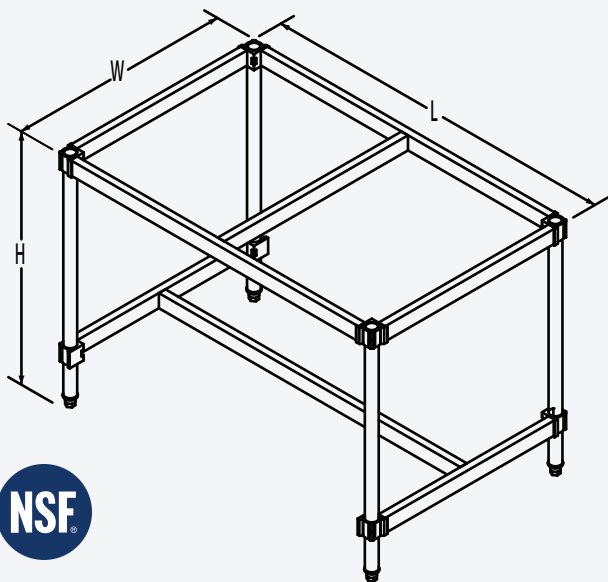

AIFT303472-PT



AIFT303472-PTBS

Poly Top I-Frame Tables			
Model Number	Description	Size W x H x L	Weight #
AIFT303424-PT	1-Piece Poly Top	30" x 34" x 24"	34
AIFT303448-PT	2-Piece Poly Top	30" x 34" x 48"	56
AIFT303472-PT	3-Piece Poly Top	30" x 34" x 72"	79
AIFT303496-PT	4-Piece Poly Top	30" x 34" x 96"	106
Poly Top I-Frame Tables with Stainless Backsplash			
Model Number	Description	Size W x H x L	Weight #
AIFT303424-PTBS	1 Pc. Poly Top*	30" x 34" x 24"	37
AIFT303448-PTBS	2 Pc. Poly Top*	30" x 34" x 48"	65
AIFT303472-PTBS	3 Pc. Poly Top*	30" x 34" x 72"	89
AIFT303496-PTBS	4 Pc. Poly Top*	30" x 34" x 96"	122



FEATURES

I-Frame Tables

- Design a table to fit your needs
- Order with or without backsplash
- Heavy-Duty 16 gauge stainless top
- All aluminum frame – Will Not Rust
- Adjustable bullet feet adjusts to 1½"
- I-Frame base
- Provides open access from both sides
- Easy lock bushing assembly
- Ships knock down"

Optional

- Adjustable 12" deep stainless steel cantilever shelf
- 18" Deep aluminum under shelf
- 72" Wide and up ship LTL

Stainless Top I-Frame Tables			
Model Number	Description	Size W x H x L	Weight #
AIFT303424-ST	Stainless Top	30" x 34" x 24"	29
AIFT303448-ST	Stainless Top	30" x 34" x 48"	46
AIFT303472-ST	Stainless Top	30" x 34" x 72"	63
AIFT303496-ST	Stainless Top	30" x 34" x 96"	87
Stainless Top I-Frame Tables with Stainless Backsplash			
Model Number	Description	Size W x H x L	Weight #
AIFT303424-STBS	Stainless Top*	30" x 34" x 24"	31
AIFT303448-STBS	Stainless Top*	30" x 34" x 48"	51
AIFT303472-STBS	Stainless Top*	30" x 34" x 72"	69
AIFT303496-STBS	Stainless Top*	30" x 34" x 96"	95

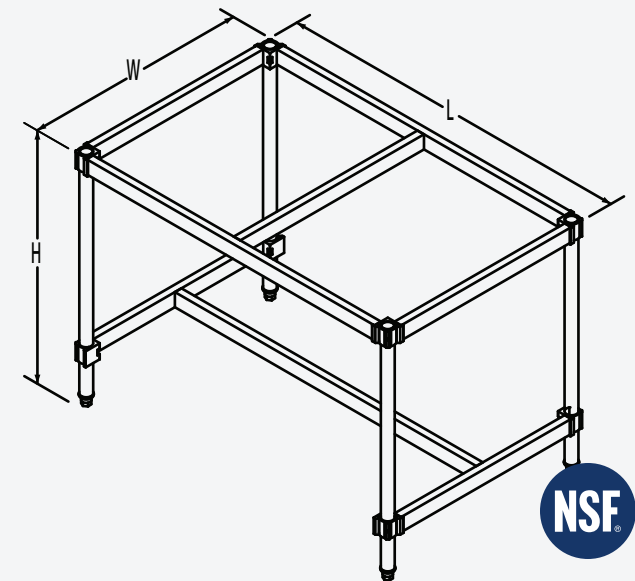

FEATURES

Wall Mount Shelves

- Ships knock down
- Easy assembly
- 1½" Backsplash
- Durable – easy clean design
- All welded corners
- Weight capacity is determined by wall anchors
(Mounting hardware not included)

Stainless Steel Wall Mount Shelves

- 300 Series stainless
- 16 Gauge gusset supports
- 18 Gauge shelf surface

Aluminum Microwave Wall Mount Shelf

- One-piece aluminum, no assembly
- 1½" Diameter hole for cord in back
- 1/8" Marine edge in front



Aluminum Microwave Wall Mount Shelf



Wall Mount Shelves				
Model Number	Description	Size D x L x H	Supports	Weight #
WS1224	Aluminum	12" x 24" x 12"	2	5
WS1236	Aluminum	12" x 36" x 12"	2	6
WS1248	Aluminum	12" x 48" x 12"	2	7.5
WS1260	Aluminum	12" x 60" x 12"	3	10
WS1272	Aluminum	12" x 72" x 12"	3	11
WS1224SS	Stainless Steel	12" x 24" x 12"	2	9
WS1236SS	Stainless Steel	12" x 36" x 12"	2	12
WS1248SS	Stainless Steel	12" x 48" x 12"	2	14
WS1260SS	Stainless Steel	12" x 60" x 12"	3	17
WS1272SS	Stainless Steel	12" x 72" x 12"	3	21
WS1284SS	Stainless Steel	12" x 84" x 12"	4	25
WS1296SS	Stainless Steel	12" x 96" x 12"	4	26
Aluminum Microwave Wall Mount Shelf				
Model Number		Size W x H x L		Weight
WM18124		18" x 12" x 24"		6



KR204736-2

FEATURES

Keg Shelving

- Heavy-Duty, easy load square-bar shelves
- Holds all keg sizes
- Adjustable bullet feet. Adjusts to 1½"
- Ships knock down with easy assembly
- Shelves bolt to posts, anti-slip gator grip clamps mean no slipping

Optional

- U-frame for side containment can be added at any time (KR2060-UF, KR2080-UF, KR2093-UF)

Keg Shelving				
Model Number	Shelf Qty.	I.D. Shelf Size W x L	O.D. Shelf Size W x L	½ Barrel Keg Capacity
KR204736-2	2	20" x 36"	20" x 40 ³ / ₈ "	4 Total, 2 per Shelf
KR204760-2	2	20" x 60"	20" x 64 ⁵ / ₈ "	8 Total, 4 per Shelf
KR204780-2	2	20" x 80"	20" x 84 ³ / ₈ "	10 Total, 5 per Shelf
KR204793-2	2	20" x 93"	20" x 97 ⁵ / ₈ "	12 Total, 6 per Shelf
KR2078560-3	3	20" x 60"	20" x 64 ⁵ / ₈ "	12 Total, 4 per Shelf
KR2078580-3	3	20" x 80"	20" x 84 ³ / ₈ "	15 Total, 5 per Shelf
KR2078593-3	3	20" x 93"	20" x 97 ⁵ / ₈ "	18 Total, 6 per Shelf
Optional U-Frame:				
Model Number	For Use With		Weight	
KR2060-UF	For Use with Models: KR204760-2 & KR2078560-3		4	
KR2080-UF	For Use with Models: KR204780-2 & KR2078580-3		5	
KR2093-UF	For Use with Models: KR204793-2 & KR2078593-3		6	

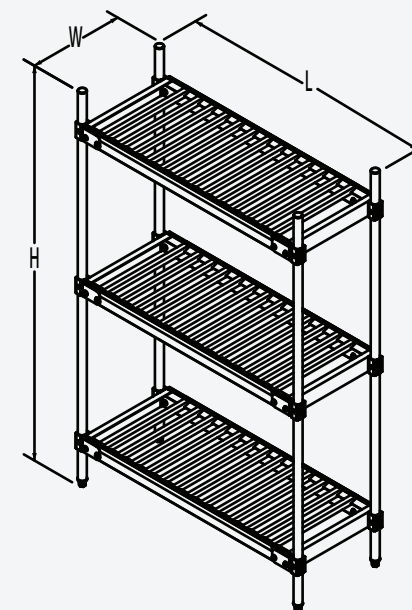

FEATURES

Nesting Dunnage Racks

- Space-saving design
May be loaded when nested
- Great for storage
- Heavy load capacity
- Heavy-duty 1/8" thick aluminum
- Easy clean design

Optional

- Plastic feet caps (DRCAP)

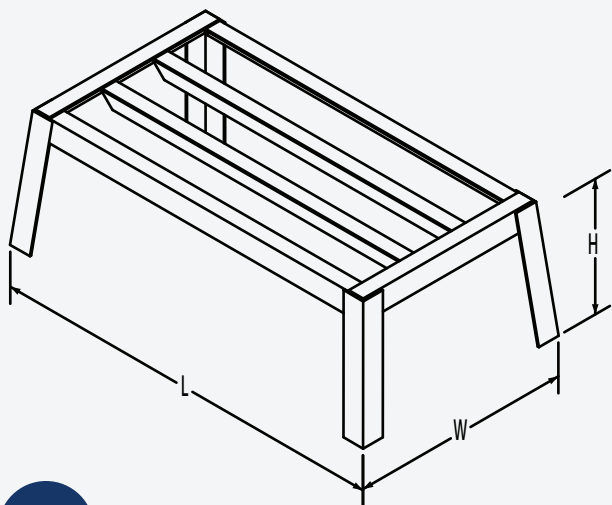
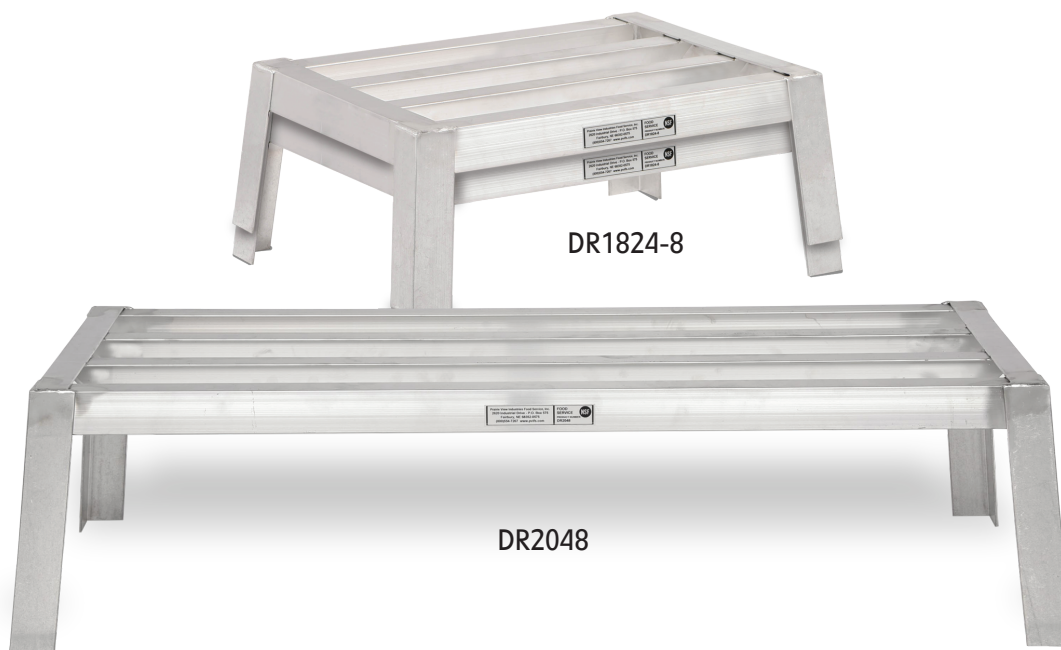

8" Nesting Dunnage Racks		
Model Number	Footprint W x L	Wt. #
DR1824-8	17¼" x 23¼"	7
DR1836-8	17¼" x 35¼"	8
DR1848-8	17¼" x 47¼"	10
DR1860-8	17¼" x 59¼"	13
DR2024-8	19¼" x 23¼"	9
DR2036-8	19¼" x 35¼"	10
DR2048-8	19¼" x 47¼"	12
DR2060-8	19¼" x 59¼"	14
DR2424-8	23¼" x 23¼"	12
DR2436-8	23¼" x 35¼"	13
DR2448-8	23¼" x 47¼"	14
DR2460-8	23¼" x 59¼"	15

12" Nesting Dunnage Racks		
Model Number	Footprint W x L	Wt. #
DR1824	18" x 24"	7
DR1836	18" x 36"	8
DR1848	18" x 48"	10
DR1860	18" x 60"	13
DR2024	20" x 24"	9
DR2036	20" x 36"	10
DR2048	20" x 48"	12
DR2060	20" x 60"	14
DR2424	24" x 24"	12
DR2436	24" x 36"	13
DR2448	24" x 48"	14
DR2460	24" x 60"	15



DG1836

FEATURES

Adjustable Dunnage Bridges

- Allows for maximum storage configuration
- Space saving design
- All welded aluminum – will not rust
- Adjusts and expands for your changing needs
- Open access for easy cleaning

Adjustable Dunnage Bridges			
Model Number	For Use With	Bridgeable Span Limit Min. to Max	Wt. #
DG1824	DR18 Models	8" to 18"	4
DG1836	DR18 Models	16" to 24"	5
DG2024	DR20 Models	8" to 18"	4
DG2036	DR20 Models	16" to 24"	6
DG2424	DR24 Models	8" to 18"	5
DG2436	DR24 Models	16" to 24"	7

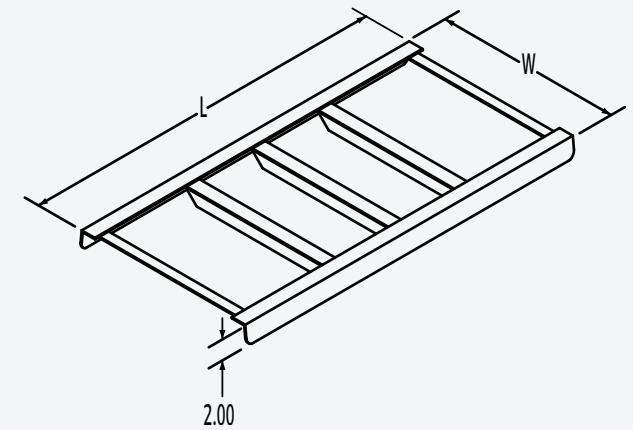

FEATURES

Single Pizza Racks

- Space-saving footprint – great for areas with limited space
- Labor-saving mobile pizza rack, proof, prep, stage, store, and transport product
- Solid sheet aluminum uprights – laser cut bent slides
- Unique design holds a variety of pan sizes:
16" wide holds: 12" – 16" and 8" – 11" pans centered
18" wide holds: 14" – 18" and 10" – 13" pans centered
- 5" Swivel stem casters (CV)
- Open slide design for easy cleaning; product is visible and reduces contamination
- KD knock-down rack – ships UPS in two boxes for easy assembly

Double Pizza Racks

- Stable transport mobile rack - ideal for large volume production
- Labor-saving mobile pizza rack; proof, prep, stage, store, and transport product
- Solid sheet aluminum uprights – laser cut bent slides
- Unique design holds a variety of pan sizes:
16" wide holds: 12" – 16" and 8" – 11" pans centered
18" wide holds: 14" – 18" and 10" – 13" pans centered
5" swivel stem casters (cv)
- Open slide design for easy cleaning, product is visible and reduces contamination
- KD knock-down rack – ships UPS in three boxes for easy assembly

Optional

- Cover available separately keeps product moist and fresh



**ASK US ABOUT OUR CASTER UPGRADE
OPTIONS AVAILABLE WHEN ORDERING**

Pizza Screen Holder

- All aluminum – will not rust
- Increases worktable space
- Holds screens and pans
- Predrilled holes allow for easy side or front mounting to table

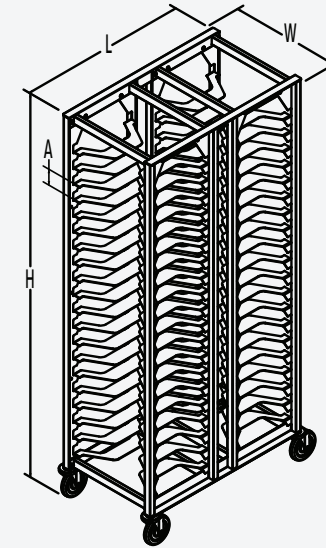
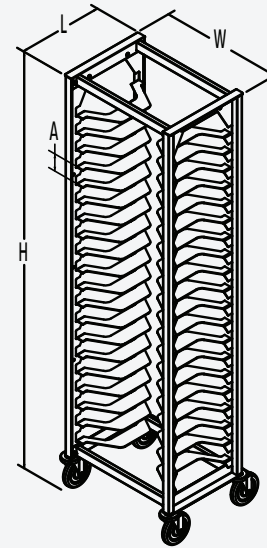

Single Pizza Racks

Model Number	"A" Shelf Spacing	"B" Open B/T Supports	"C" I.D. Width	"D" O.D. Width	Pan Capacity	Weight #
LPZ3016	3"	2 7/8"	16 1/2"	18 3/4"	20	37
LPZ2516	2 1/2"	2 3/8"	16 1/2"	18 3/4"	24	37
LPZ3018	3"	2 7/8"	18 1/2"	20 3/4"	20	38
LPZ2518	2 1/2"	2 3/8"	18 1/2"	20 3/4"	24	38

Double Pizza Racks

LPZ3016-DB	3"	2 7/8"	16 1/2"	s"	40	65
LPZ2516-DB	2 1/2"	2 3/8"	16 1/2"	18 3/4"	48	65
LPZ3018-DB	3"	2 7/8"	18 1/2"	20 3/4"	40	66
LPZ2518-DB	2 1/2"	2 3/8"	18 1/2"	20 3/4"	48	66

Optional Translucent Cover And Screen Holder

Model Number	Description
VYSG-T	Clear front loading panel for single racks with zippers on two corners
VYDB-T	Clear front loading panel for double racks with zippers on two corners
SPZ518	Holds up to 18" screens

FEATURES

Nesting Pan Rack

- Space-saving "Z" type rack; nests when empty for storage
- Horizontal "Z" type supports; 1½" x ⅜" heavy-duty tubing with reinforced gusset corners
- 1" H x 1½" W aluminum slides welded to frame
- Holds standard 18" x 26" sheet pans
- 5" Swivel Stem Casters (CV)
- Laser cut – ready to use; ships LTL

Optional

- Locking casters (CL)
- Heavy-Duty swivel Casters (CHV)
- Heavy-Duty locking Casters (CHL)
- Covers – call for quote

PVI retains the right to modify our products without notice.

At PVI, we constantly aim to improve our products, ensuring they are stronger, lighter, and simpler to maintain and transport. We are thrilled to unveil our new laser-cut Z racks, which contribute to this objective. At PVI, customer satisfaction is our highest priority.

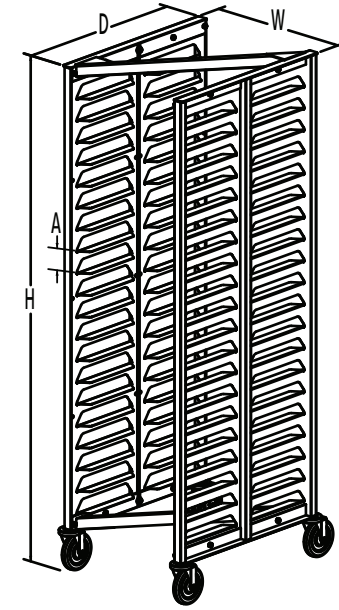

LE3018-Z

"Z" Type Nesting Pan Racks

Model Number	Description	Size W x H x D	"A" Shelf Spacing	Pan Capacity
LE2018-Z	End Load	20½x71½"x26"	2"	30
LE3018-Z	End Load	20½x71½"x26"	3"	20
LE4018-Z	End Load	20½x71½"x26"	4"	15
LE5018-Z	End Load	20½x71½"x26"	5"	12
LE6018-Z	End Load	20½x71½"x26"	6"	10
LS2026-Z	Side Load	28½x71½"x18"	2"	30
LS3026-Z	Side Load	28½x71½"x18"	3"	20
LS4026-Z	Side Load	28½x71½"x18"	4"	15
LS5026-Z	Side Load	28½x71½"x18"	5"	12
LS6026-Z	Side Load	28½x71½"x18"	6"	10



At PVI, we constantly aim to improve our products, ensuring they are stronger, lighter, and simpler to maintain and transport. We are thrilled to unveil our new laser-cut Z racks, which contribute to this objective. At PVI, customer satisfaction is our highest priority.

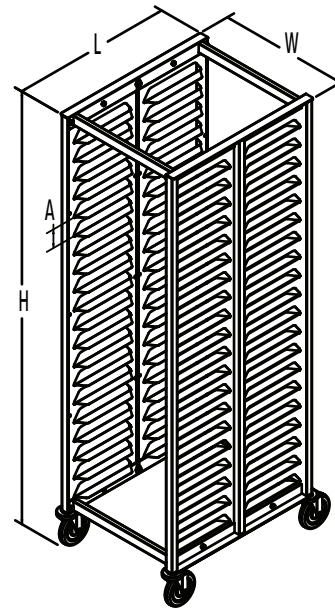

LE3020-SP

FEATURES

Steam Pan Rack

- 1" H x 1 1/2" w aluminum slides laser cut
- Holds following pan sizes by the lip
 - Full size 20 3/4" x 12 3/4"
 - Half size 10 3/8" x 12 3/4"
 - Two-third size 13 7/8" x 12 3/4"
 - One-third size 6 7/8" x 12 3/4"
- 5" Heavy duty swivel stem casters (chv)
- "Kd" knock down rack
- Ships UPS in one box
- Assembles with 12 fasteners
- "L" laser cut rack
- Reinforced gusset corners
- Ships LTL

Optional

- Locking casters (CL)
- Heavy-duty swivel casters (CHV)
- Heavy-duty locking casters (CHL)
- Pan stop (PS)

PVI retains the right to modify our products without notice.

Steam Pan Rack

Model Number	Description	Size W x H x D	"A" Shelf Spacing	Pan Capacity
LE3020KD-SP	"KD" End Load	17"x71 1/2"x20"	3"	18
LE5020KD-SP	"KD" End Load	17"x71 1/2"x20"	5"	12
LE3020W-SP	End Load	17"x71 1/2"x20"	3"	18
LE5020W-SP	End Load	17"x71 1/2"x20"	5"	12



FEATURES

Poly box

- Organize, store & transport foods
- 1" H x 1½" w aluminum slides welded to frame
- Holds 18" X 26" or 18" x 13" poly food boxes manufactured by cambro®, carlisle®, continental® or rubbermaid®
- 5" Swivel stem casters (cv)
- All aluminum – will not rust
- "Kd" knock down rack
Ships ups in one box
Assembles with 12 xfasteners
- "L" laser cut
Reinforced gusset corners
Ships LTL

Optional

- Locking casters (cl)
- Heavy-duty swivel casters (chv)
- Heavy-duty locking casters (chl)
- Pan stop (ps)
- Cover (vyre-c)

PVI retains the right to modify our products without notice.

At PVI, we constantly aim to improve our products, ensuring they are stronger, lighter, and simpler to maintain and transport. We are thrilled to unveil our new laser-cut racks, which contribute to this objective. At PVI, customer satisfaction is our highest priority.

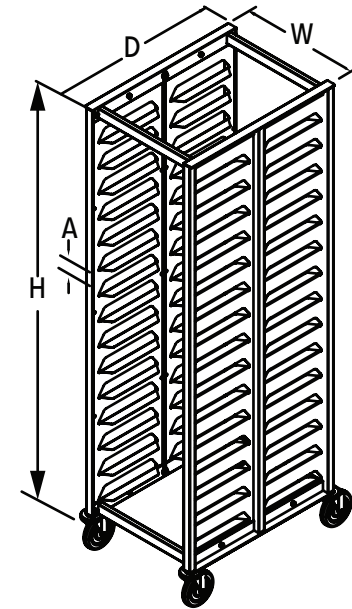

LE40195KD-PB

Poly Box			
Model Number	Description	"A" Shelf Spacing	Pan Capacity
LE40195KD-PB	"KD" End Load	4"	14
LE70195KD-PB	"KD" End Load	7"	7
LE10195KD-PB	"KD" End Load	10"	6
LE40195W-PB	Laser Cut End Load	4"	14
LE70195W-PB	Laser Cut End Load	7"	7
LE10195W-PB	Laser Cut End Load	10"	6



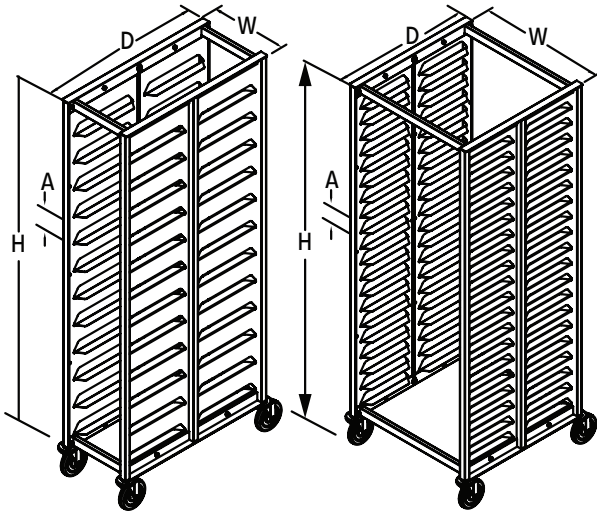

At PVI, we constantly aim to improve our products, ensuring they are stronger, lighter, and simpler to maintain and transport. We are thrilled to unveil our new laser-cut racks, which contribute to this objective. At PVI, customer satisfaction is our highest priority.



FEATURES

Platter Rack

- Store, transport and prep 30" long platter trays
- 1" H x 1½" w aluminum slides laser cut to frame
- Holds either 10" or 12" wide trays
- 5" Swivel stem casters (CV)
- All aluminum – will not rust
- "Kd" knock down rack
Ships LTL
Assembles with 12 fasteners
- "L" laser cut rack
Reinforced gusset corners
Ships LTL

Donut Screen Rack

- 1" H x 1½" w aluminum slides
3" spacing
Lase cut
- Holds various sizes (listed below)
- 5" Swivel stem casters (cv)
- All aluminum – will not rust
- "Kd" knock down rack
Ships ups in one box
Assembles with 12 fasteners
- "L" laser cut rack
Reinforced gusset corners
Ships LTL

Optional

- Locking casters (CL)
- Heavy-duty swivel casters (CHV)
- Heavy-duty locking casters (CHL)
- Pan stop (PS)

PVI retains the right to modify our products without notice.

Platter Rack				
Model Number	Description	Size W x H x D	"A" Shelf Spacing	Pan Capacity
LE5010KD -PL	Knock Down	12 1/4" x 71 1/2" x 30"	5"	12
LE5010W -PL	Laser Cut	12 1/4" x 71 1/2" x 30"	5"	12
LE6010KD-PL	Knock Down	12 1/4" x 71 1/2" x 30"	6"	10
LE6010W-PL	Laser Cut	12 1/4" x 71 1/2" x 30"	6"	10
LE5012KD-PL	Knock Down	14 3/4" x 71 1/2" x 30"	5"	12
LE5012W-PL	Laser Cut	14 3/4" x 71 1/2" x 30"	5"	12
LE6012KD-PL	Knock Down	14 3/4" x 71 1/2" x 30"	6"	10
LE6012W-PL	Laser Cut	14 3/4" x 71 1/2" x 30"	6"	10
Donut Screen Rack				
Model Number	Description	Dimensions W x D	Holds Screen Size	
LE302323KD-DSR	Knock Down End Load	25 1/2" x 24"	23" x 23"	
LE302323W-DSR	Laser Cut End Load	25 1/2" x 24"	23" x 23"	
LE302424KD-DSR	Knock Down End Load	26 1/2" x 24"	24" x 24"	
LE302424W-DSR	Laser Cut End Load	26 1/2" x 24"	24" x 24"	
LE302333KD-DSR	Knock Down End Load	25 1/2" x 30"	23" x 33"	
LE302333W-DSR	Laser Cut End Load	25 1/2" x 30"	23" x 33"	

FEATURES

L-Series Assembled & Knock Down Pan Racks

- Solid sheet uprights
- Laser cut, bent slides 1½" w
- Holds standard 18" x 26" sheet pans
- 5" Swivel stem casters (CV)
- KD knock down rack ships UPS in one box
assembles with 12 fasteners
- A fully assembled rack Ships LTL

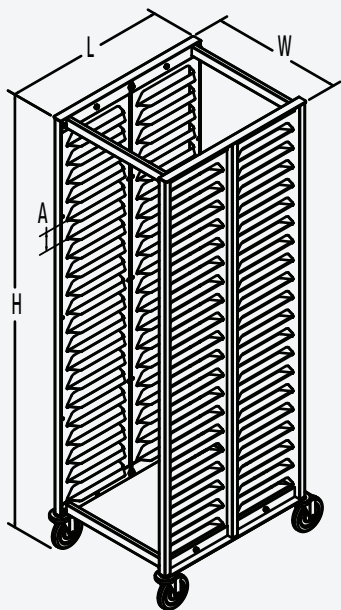

L-Series Assembled & "KD" Knock Down Pan Racks

Model Number	Add to Suffix		Description	"A" Shelf Spacing	PanCapacity
LE3018	KD	A	End Load	3"	20
LE4018	KD	A	End Load	4"	15
LE5018	KD	A	End Load	5"	12
LE6018	KD	A	End Load	6"	10





CR072C



CR162C

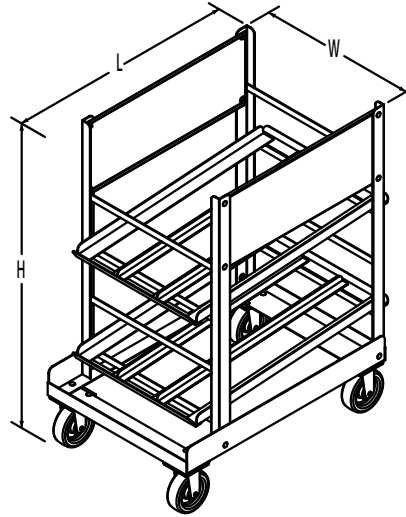

FEATURES

Half Size and Full Size Can Racks

- Holds six (6) #10 cans or eight (8) #5 cans per row three (3) rows per shelf
- Shelves remove for easy cleaning
- All aluminum – will not rust
- Can be loaded from front or rear
- Self-feeding inclined can slides
- KD knock down rack ships UPS for easy assembly
- Optional caster base may be added at any time (CR000C)
6" x 2" casters, two (2) rigid (CRPR-6) and two (2) swivel (CVPS-6)

Optional

Tops: Stainless steel, aluminum and poly (ST, AT, PT)

**ASK US ABOUT OUR CASTER UPGRADE
OPTIONS AVAILABLE WHEN ORDERING**

Half Size Can Racks					
Model Number	Size W x H x L	Capacity #10 Cans	Capacity #5 Cans	Casters	Weight #
CR0540	25" x 32" x 36"	54	72	None	38
CR054C	25" x 40" x 36"	54	72	2 Rigid 2 Swivel	62
CR054C-36	25" x 36" x 36"	54	72	2 Rigid 2 Swivel	62
CR0720	25" x 40" x 36"	72	96	None	46
CR072C	25" x 48" x 36"	72	96	2 Rigid 2 Swivel	71
Full Size Can Racks					
Model Number	Size W x H x L	Capacity #10 Cans	Capacity #5 Cans	Casters	Weight #
CR1620	25" x 72" x 36"	162	216	None	79
CR162C	25" x 80" x 36"	162	216	2 Rigid 2 Swivel	102
Optional Caster Base					
Model Number	Description				
CR000C	Fits all PVI can racks, includes casters and all hardware.				



FEATURES

Equipment Stands

- Heavy-Duty, solid adjustable shelves
400 lb. capacity per shelf
- Smooth, solid surface
easy to clean
- Easy lock bushing assembly
- Ships knock down UPS

Optional

- Swivel casters (CV)
- Locking casters (CL)
- Heavy-Duty swivel Casters (CHV)
- Heavy-Duty locking Casters (CHL)
- Tops provide a flat surface:
- Aluminum and stainless (AT ST)
- Bumpers (B)

**ASK US ABOUT OUR CASTER UPGRADE
OPTIONS AVAILABLE WHEN ORDERING**



A182424-2

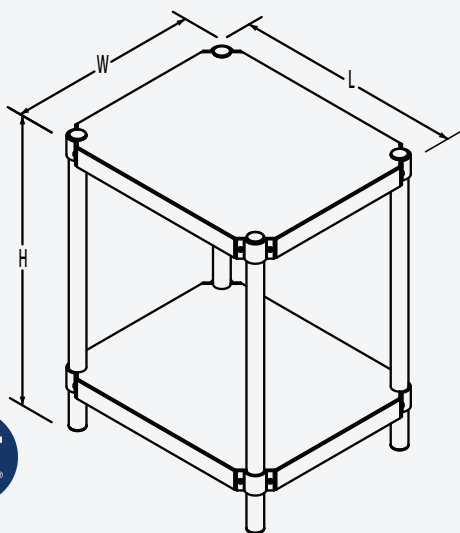

Equipment Stands		
Model Number	Size W x H x L	Weight
A182424-2	18" x 24" x 24"	15
A183024-2	18" x 30" x 24"	16
A182436-2	18" x 24" x 36"	20
A183036-2	18" x 30" x 36"	21
A202424-2	20" x 24" x 24"	17
A203024-2	20" x 30" x 24"	18
A202436-2	20" x 24" x 36"	23

Equipment Stands		
Model Number	Size W x H x L	Weight
A203036-2	20" x 30" x 36"	24
A242424-2	24" x 24" x 24"	19
A243024-2	24" x 30" x 24"	20
A242430-2	24" x 24" x 30"	22
A243030-2	24" x 30" x 30"	23
A242436-2	24" x 24" x 36"	25
A243036-2	24" x 30" x 36"	26



A206048-4-CHL2

FEATURES

Mobile Aluminum Shelving Units

- 400 lb. capacity per shelf
- Heavy-Duty, solid adjustable shelves
- Smooth solid surface, easy to clean
- All aluminum – will not rust
- Easy lock bushing assembly
- Ships knock down UPS
- Heavy-Duty stem casters
Two (2) 5" swivel (CHL)
Two (2) 5" swivel locking (CHV)

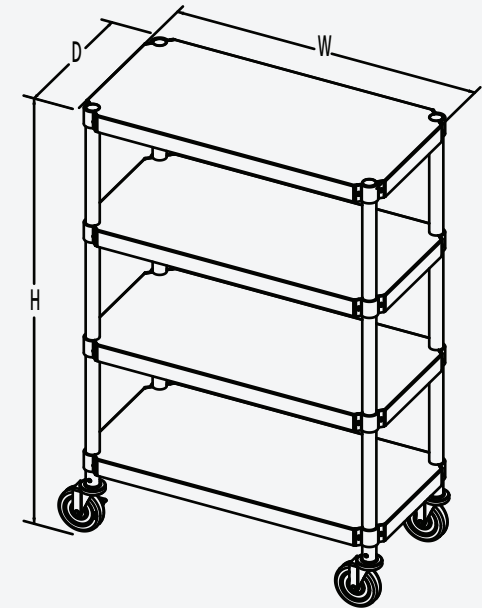

Mobile Aluminum Shelving Units		
Model Number	Size W x H x L	Weight
A204836-4-CHL2	20" x 54" x 36"	40
A204848-4-CHL2	20" x 54" x 48"	48
A204860-4-CHL2	20" x 54" x 60"	56
A206036-4-CHL2	20" x 66" x 36"	48
A206048-4-CHL2	20" x 66" x 48"	56
A206060-4-CHL2	20" x 66" x 60"	64

Mobile Aluminum Shelving Units		
Model Number	Size W x H x L	Weight
A244836-4-CHL2	24" x 54" x 36"	44
A244848-4-CHL2	24" x 54" x 48"	60
A244860-4-CHL2	24" x 54" x 60"	68
A246036-4-CHL2	24" x 66" x 36"	52
A246048-4-CHL2	24" x 66" x 48"	64
A246060-4-CHL2	24" x 66" x 60"	74

**ASK US ABOUT OUR CASTER UPGRADE
OPTIONS AVAILABLE WHEN ORDERING**







WUC2024



AUC2036



All Welded Aluminum Utility Carts

Model Number	O.D. Size W x H x L	O.D. Shelf Size W x L	Deck Height	Weight
WUC2024	20" x 41" x 30"	20" x 24"	30"	25
WUC2036	20" x 41" x 42"	20" x 36"	30"	29
WUC2048	20" x 41" x 54"	20" x 48"	30"	33
WUC2060	20" x 41" x 66"	20" x 60"	30"	37

Aluminum Utility Carts

Model Number	Size W x L	Weight #
AUC1824	18" x 24"	22
AUC1836	18" x 36"	26
AUC1848	18" x 48"	31
AUC2024	20" x 24"	24
AUC2036	20" x 36"	28
AUC2048	20" x 48"	33
AUC2424	24" x 24"	26
AUC2430	24" x 30"	28
AUC2436	24" x 36"	30
AUC2448	24" x 48"	35

Mat Cart

Model Number	Size W x L	Weight #
MCA344636	34" x 46" x 36"	44



MCA344636

FEATURES

All Welded Aluminum Utility Carts

- Work-Saving mobile cart
- Use for prepping, transporting and storage of all types of products
- Heavy-Duty frame
900 lb. load capacity
2" T-Bar center supports
1" x 1" Tubing
- Plate casters
Four (4) heavy-duty 4" x 2" swivel plate (CVPS-4)
- All welded aluminum – will not rust
- Ships LTL

Optional

Heavy-Duty 4" x 2" locking swivel plate casters (CLPS-4)
Heavy Duty 4" x 2" rigid casters (CRPS-4)

Aluminum Utility Carts

- Adjustable handle and shelves
- Smooth, solid surface; easy to clean
- 400 lb. Capacity per shelf
- 5" Swivel stem casters (CV)
- Easy lock bushing assembly
- 36" Work surface height
- Ships knock down UPS

Optional

Additional shelf
Tops: Aluminum and stainless (AT, ST)
Heavy-Duty swivel casters (CHV)
Heavy-Duty locking casters (CHL)
Locking casters (CL)
Bumpers (B)

FEATURES

Bulk Movers

- Work-Saving mobile carts
- 1½" Diameter, easy grip frame, open easy clean design
- Heavy-Duty 5" swivel stem casters (CHV)
- All aluminum will not rust
- NSF certified

Tubs

- Seamless polyethylene, FDA approved natural bulk tubs, shoebox type lids
- Variety of tub sizes:
 4 Bushel (30 gallon capacity)
 6 Bushel (41 gallon capacity)
 8 Bushel (57 gallon capacity)
 9 Bushel (66 gallon capacity)

Options

Two (2) 5" swivel locking (CHL)

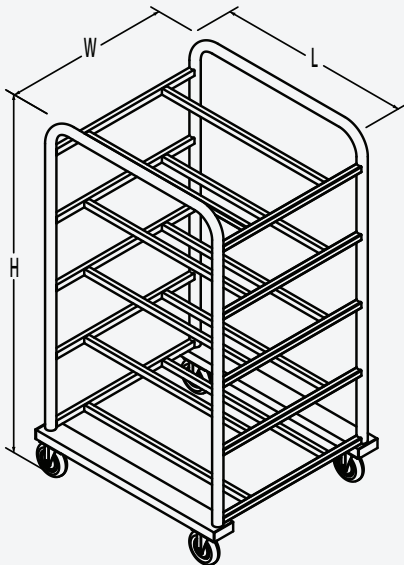

LUGCT1BK8



LUGCT1BK8

Bulk Movers					
Model Number	Description	O.D. Top L x W x H	I.D. Top L x W	I.D. Bottom L x W	Weight #
LUGNBL4	4 Bushel Lid	34" x 22½" x 2"	—	—	4
LUGNBL6	6 Bushel Lid	33½" x 24½" x 2"	—	—	6
LUGNBL8	8 Bushel Lid	37½" x 25" x 2½"	—	—	9
LUGNBL9	9 Bushel Lid	37½" x 25" x 2½"	—	—	9
LUGNBT4	4 Bushel Tub	32¾" x 21¼" x 15¾"	29¼" x 17½"	24¾" x 15"	12
LUGNBT6	6 Bushel Tub	32¼" x 23¼" x 20"	29" x 20"	23½" x 16"	13
LUGNBT8	8 Bushel Tub	36¼" x 24¼" x 23"	32¼" x 20½"	28½" x 17"	23
LUGNBT9	9 Bushel Tub	41½" x 29½" x 19"	37" x 25"	33" x 21"	25
LUGCT1BK4	4 Bushel Cart	30¼" x 20½" x 30½"	—	—	19
LUGCT1BK6	6 Bushel Cart	28" x 22¼" x 26¼"	—	—	19
LUGCT1BK8	8 Bushel Cart	33" x 22¼" x 23"	—	—	23
LUGCT1BK9	9 Bushel Cart	37½" x 27" x 27"	—	—	24
LUGCT1BK4-NBT	4 Bushel Cart & Tub	32¾" x 21¼" x 36"	—	—	31
LUGCT1BK6-NBT	6 Bushel Cart & Tub	32¼" x 23¼" x 36"	—	—	32
LUGCT1BK8-NBT	8 Bushel Cart & Tub	36¼" x 24¼" x 36"	—	—	46
LUGCT1BK9-NBT	9 Bushel Cart & Tub	41½" x 29½" x 36"	—	—	49





P20836T



D1525323











D19322-HAND

Platform Trucks

Model Number	Size W x H x L	O.D. Length	Weight #
P20836T	20" x 13" x 36"	38"	44
P20848T	20" x 13" x 48"	50"	48
P20860T	20" x 13" x 60"	62"	52
P30848T	30" x 13" x 48"	50"	62
P30860T	30" x 13" x 60"	62"	68

Flat Dollies

Model Number	Description	Size W x H x L	Weight
 D19322	19" x 22", Chill Tray	19" x 6" x 22"	14
 D21321	Glass Rack	21" x 6" x 21"	14
 D18326	18" x 26" Bun/Dough Pan	18" x 6" x 26"	14
 D17326	Lug Rack	17" x 6" x 26"	13
 D1525323	Chicken Case	15¼" x 6" x 23"	12
 D19322-HAND	19" x 22", Chill Tray with Handle	19" x 32" x 24"	18
 D21321-HAND	Glass Rack with Handle	21" x 32" x 23"	18
 D18326-HAND	18" x 26" Bun/Dough Pan with Handle	18" x 32" x 28"	18
 D17326-HAND	Lug Rack with Handle	17" x 32" x 28"	17

FEATURES

Platform Trucks

- Heavy-Duty, grooved I-Beam planks
- Quiet ride, heavy-duty, 8" x 2" donut plate casters, 2 rigid – 2 swivel
- 1½" Diameter, easy grip handle easily bolts to frame
- Ships knock down

Flat Dollies

- Solid one-piece design
- Easy to clean open corners
- Heavy-Duty polyolefin plate casters; 3" x 1¼" swivel, plate (CDPV3)
- Available with or without handle
- Ships knock down for easy assembly
- Ships UPS in one box

Options

Locking casters (CDPL3)

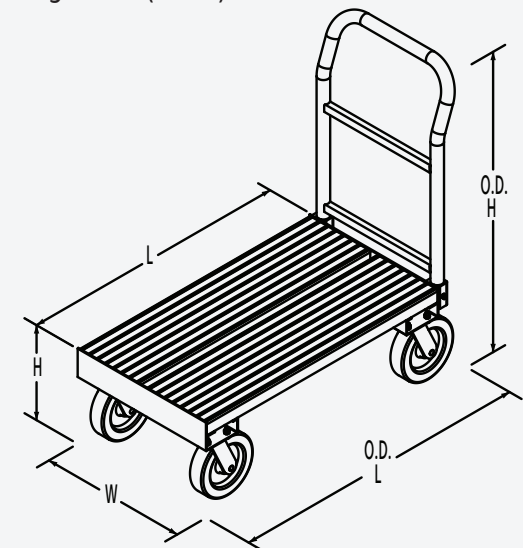

FEATURES

Chill Tray Dollies

- Flow-Through open base design allows for maximum circulation
- Heavy-Duty transport dollies ideal for cook/chill systems
- All aluminum – will not rust
- Quiet ride 4" x 2" plate casters
450 lb. capacity Each
Two (2) rigid (CRPS-4)
Two (2) swivel (CVPS-4)
- Available with or without Handle
- Ships knock down for easy assembly

Caster Upgrade Option Available

- Locking plate casters (CLPS-4)

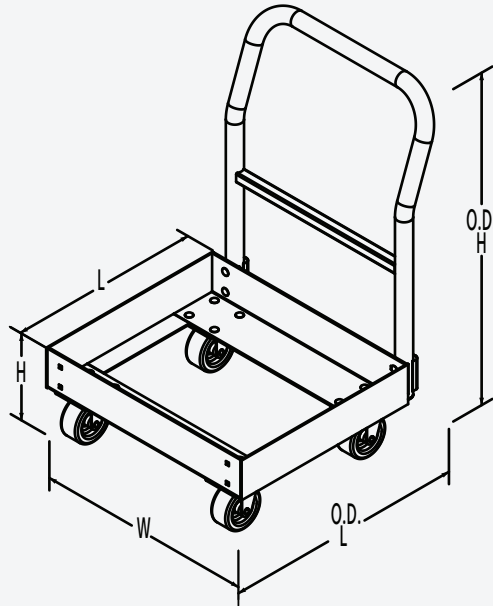

CHILL1-CHILLHAND

CHILL2-CHILLHAND

Chill Tray Dollies			
Model Number	Size W x H x L	Deck Height	Weight
CHILL1	Single	22 3/4" x 10" x 19"	16
CHILL2	Double	22 3/4" x 10" x 39"	19.5
CHILL3	Triple	22 3/4" x 10" x 60"	22.5
CHILL1-CHILLHAND	Single w/ Handle	22 3/4" x 37 1/4" x 25 1/2"	33
CHILL2-CHILLHAND	Double w/ Handle	22 3/4" x 37 1/4" x 46"	36
CHILL3-CHILLHAND	Triple w/ Handle	22 3/4" x 37 1/4" x 66 3/4"	39
CHILL2-CHILLHAND2	Double w/ Two (2) Handles	22 3/4" x 37 1/4" x 52"	49
CHILL3-CHILLHAND2	Triple w/ Two (2) Handles	22 3/4" x 37 1/4" x 72 3/4"	56



FEATURES

Workstations

- 16 Gauge stainless steel work top; with 6" backsplash
- Top is removeable for easy cleaning
- Heavy-Duty all aluminum frame, posts, and base shelf – will not rust
- Solid one-piece shelves
- Adjustable cantilever and base shelves
- Easy Lock Bushing assembly
- Ships Knock Down

Workstations		
Model Number	Description	Size W x H x L
W307236	Two (2), 12" W Cantilever Shelves	30" X 72" X 36"
W307248	Two (2), 12" W Cantilever Shelves	30" X 72" X 48"
W307260	Two (2), 12" W Cantilever Shelves	30" X 72" X 60"
Additional Cantilever Shelves		
Model Number	Size W x L x H	Weight #
CANT1236	12" x 36" x 2"	4
CANT1248	12" x 48" x 2"	6
CANT1260	12" x 60" x 2"	8
CANT1836	18" x 36" x 2"	6
CANT1848	18" x 48" x 2"	8
CANT1860	18" x 60" x 2"	10

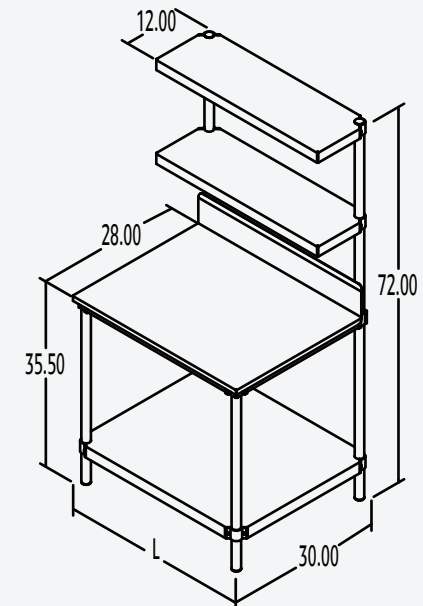

FEATURES

24" Retractable Prep Stations Wall Mount and Mobile

- Available in 36" and 48" wide models both with under shelf and cantilever shelf
- 16 Gauge stainless steel construction
- Space-Saver – folds up to be moved and/or stored for easy clean up
- Work surface weight capacity – 500 lbs. (evenly distributed load)
- 24" Deep work surface has 1¾" backsplash on 3 sides
- Safety pins provided for added security
- Wall mount model comes fully assembled with mounting hardware for drywall and stud installation; mounts 6" off the floor
- Make unit mobile by adding optional caster base* minimal assembly required; four 3" x 1¼" swivel locking casters (CDL3)

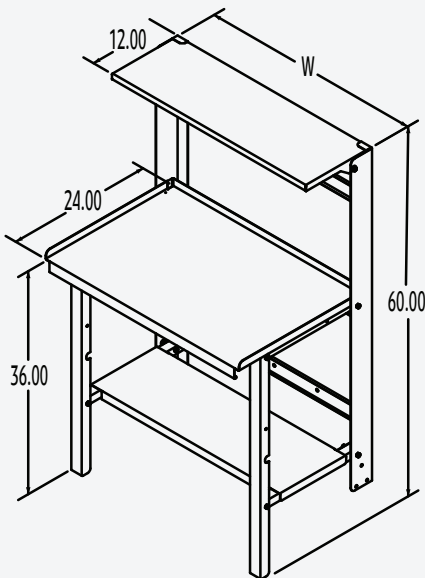

Retractable Prep Station



Retractable Prep Station Folded



RTW246036C

24" Retractable Prep Stations			
Model Number	Closed Size* D x H x W	Opened Size D x H x W	Weight
RTW246036	5 ¼" x 60" x 36"	24" x 60" x 36"	68
RTW246048	5 ¼" x 60" x 48"	24" x 60" x 48"	82
Mobile Retractable Prep Stations			
Model Number	Closed Size* D x H x W	Opened Size D x H x W	Weight
RTW246036C	17" x 60" x 36"	24" x 60" x 36"	94
RTW246048C	17" x 60" x 48"	24" x 60" x 48"	112
Optional Caster Bases			
Model Number	Description		
RT36C	36" Caster Base; Compatible with RTW246036		
RT48C	48" Caster Base; Compatible with RTW246048		



CADAL

RH6128

RH8.511

CPOS2236SS

FEATURES

Drip Catchers

- Edge of table drip tray
- Keeps floors clean
- 8" Wide back protects from splashes
- Available in stainless steel or aluminum
- 6" Front drop with 2.9" diameter hole
- Holds most 8 oz. to 12 oz. cups

Recipe Holders

- All aluminum
- Large capacity 3" rings – 3¼" between holes
- Holds 8" x 6" recipe cards or 8.5" x 11" sheets
- Padded feet protects countertop

Stainless Steel Corner Guards

- 2" x 2" Inside or outside protectors
Slightly pitched beyond 90 degrees for a tight fit
- Offered in a variety of heights
- Available in 16 gauge stainless steel or aluminum
- Custom heights available upon request at additional cost

Drip Catcher			
Model Number	Description	Size W x D	Weight
CADAL	Aluminum	8" x 11"	1
CADSS	Stainless Steel	8" x 11"	3
Recipe Holders			
Model Number	Size W x H x L	Weight	
RH6128	6" x 11" x 8"	1.5	
RH8.511	8½" x 13½" x 8½"	3	
Stainless Steel Corner Guards			
Model Number	Description	Size W x H x L	Weight
CPOS2236SS	Outside	2" x 36" x 2"	2.5
CPIS2236SS	Inside	2" x 36" x 2"	2.5
CPOS2248SS	Outside	2" x 48" x 2"	3.25
CPIS2248SS	Inside	2" x 48" x 2"	3.25
CPOS2260SS	Outside	2" x 60" x 2"	4
CPIS2260SS	Inside	2" x 60" x 2"	4
CPOS2272SS	Outside	2" x 72" x 2"	5
CPIS2272SS	Inside	2" x 72" x 2"	5





Residential



Restaurants



Commercial Spaces



Hospitals



Catering Halls



Event Spaces



Convention Centers



Airports



Schools

Prairie View Industries Limited Warranty

1. LIMITED LIFETIME WARRANTY—THE FOLLOWING APPLIES TO ALL END PURCHASERS OTHER THAN RESIDENTS OF THE STATE OF CALIFORNIA*: PRAIRIE VIEW INDUSTRIES, INC. warrants to the original end purchaser of the product that the product is free from defects in material and workmanship under normal use and service. This warranty does not apply to any product that has been subject to misuse, abuse, neglect, alteration, accident, usage not in accordance with product instructions, acts of God, or improper installation, or that has been used for rental purposes or repaired by someone other than PRAIRIE VIEW INDUSTRIES, INC. This warranty does not cover normal deterioration of the product due to wear and exposure.

*(FIVE YEAR WARRANTY—THE FOLLOWING APPLIES TO RESIDENTS OF THE STATE OF CALIFORNIA: For a period of five years after the purchase of the product by the original end purchaser of the product, PRAIRIE VIEW INDUSTRIES, INC. warrants to the original end purchaser of the product that the product is free from defects in material and workmanship under normal use and service. This warranty does not apply to any product that has been subject to misuse, abuse, neglect, alteration, accident, usage not in accordance with product instructions, acts of God, or improper installation, or that has been used for rental purposes or repaired by someone other than PRAIRIE VIEW INDUSTRIES, INC. This warranty does not cover normal deterioration of the product due to wear and exposure.)

2. This warranty is limited to repairing or replacing, at the option of PRAIRIE VIEW INDUSTRIES, INC., any product that is returned to PRAIRIE VIEW INDUSTRIES, INC. and is reasonably determined by PRAIRIE VIEW INDUSTRIES, INC. to be defective. The repair or replacement of a defective product under this warranty will be made by PRAIRIE VIEW INDUSTRIES, INC. without charge for parts or labor. This excludes shipping or delivery charges to and from PRAIRIE VIEW INDUSTRIES, INC.'s place of business. If the product has been discontinued, PRAIRIE VIEW INDUSTRIES, INC. may replace the product with a new product of comparable value and function. PRAIRIE VIEW INDUSTRIES, INC. also reserves the right to refund the purchase price as its exclusive warranty remedy.

3. Any claim alleging that the product fails to conform to this warranty may be made only by the original end purchaser and only while such purchaser owns the product. A defective product that is covered by this warranty must be returned, at the purchaser's expense, along with proof of date of original purchase (such as receipt, check or other document PRAIRIE VIEW INDUSTRIES, INC. deems acceptable that shows the date of purchase and the identity of the product and purchaser), along with a description of the alleged defect, to PRAIRIE VIEW INDUSTRIES, INC., 2620 Industrial Drive, Fairbury, Nebraska 68352.

4. EXCEPT AS SET FORTH HEREIN, PRAIRIE VIEW INDUSTRIES, INC. MAKES NO WARRANTIES, EXPRESSED OR IMPLIED, AND PRAIRIE VIEW INDUSTRIES, INC. DISCLAIMS AND NEGATES ALL OTHER WARRANTIES, INCLUDING, WITHOUT LIMITATION, IMPLIED WARRANTIES OF MERCHANTABILITY, FITNESS FOR A PARTICULAR PURPOSE, CONFORMITY TO MODELS OR SAMPLES, OR ANY WARRANTIES OR INDEMNITIES AGAINST INTELLECTUAL PROPERTY INFRINGEMENT. SOME STATES DO NOT ALLOW LIMITATIONS ON IMPLIED WARRANTIES, SO THESE LIMITATIONS MAY NOT APPLY TO YOU. IN NO EVENT WILL PRAIRIE VIEW INDUSTRIES, INC. BE LIABLE FOR ANY INDIRECT, SPECIAL, INCIDENTAL, OR CONSEQUENTIAL DAMAGES OR FOR ANY LIABILITY IN EXCESS OF THE PURCHASE PRICE OF THE PRODUCT.

5. Before using the product, the purchaser must first determine the suitability of the product for its intended use, and the purchaser assumes all risk and liability whatsoever in connection therewith.

6. No person, agent, distributor, dealer or company is authorized to change, amend or modify the terms of this warranty.

7. This warranty gives the purchaser specific legal rights, and the purchaser may also have other rights that vary from state to state.

8. The purchaser may not assign the purchaser's rights or obligations under this warranty without the prior written consent of PRAIRIE VIEW INDUSTRIES, INC.

Prairie View Industries Food Service, Inc.

2620 Industrial Drive • PO Box 575 • Fairbury, NE 68352-0575

Phone: 800-554-7267 • Fax: 402-729-4058 • Web Page: pvimanufacturing.com



Prairie View Industries

Quality - Durability - Guaranteed

With superior quality equipment we've been supplying the food service industry since 1999 with products made in the U.S.A.

Explore our full range of food service equipment at www.pvimanufacturing.com and discover the PVI difference!

Contact Your Dealer Today!



PRAIRIE VIEW INDUSTRIES | 800-554-7267 | PVIMANUFACTURING.COM

2620 INDUSTRIAL AVE | FAIRBURY, NE 68352